

HH-150 Technical Specifications

Production Curve

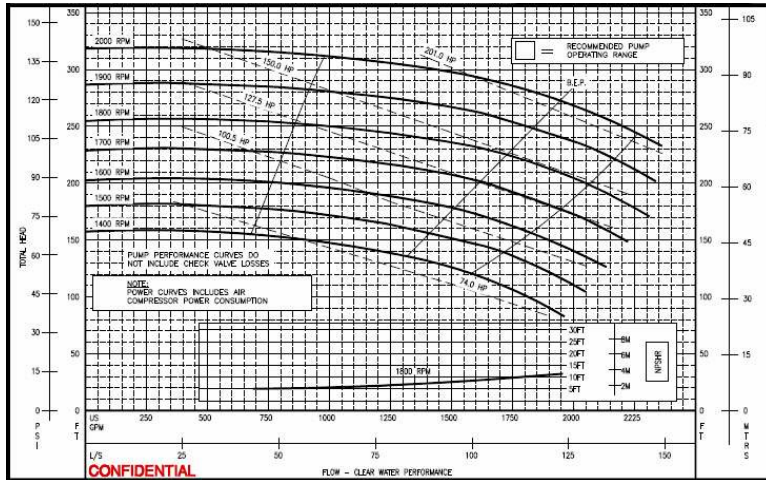

Performance Specs

STANDARD 3 VANE IMPELLER

Minimum Operating Speed:	1400 rpm
Maximum Operating Speed:	2000 rpm
Maximum Head:	325 ft.
Maximum Flow:	2,300 gpm

Design Details

Pump Designation:	HH-150
Pump Description:	Centrifugal end suction pump, single stage, volute type, fully open impeller
Solid Handling Size:	1.5inches (38mm)
Operating Temperature	MIN: -4°F (-20°C) MAX: +212°F (+100°C)

Dimensions

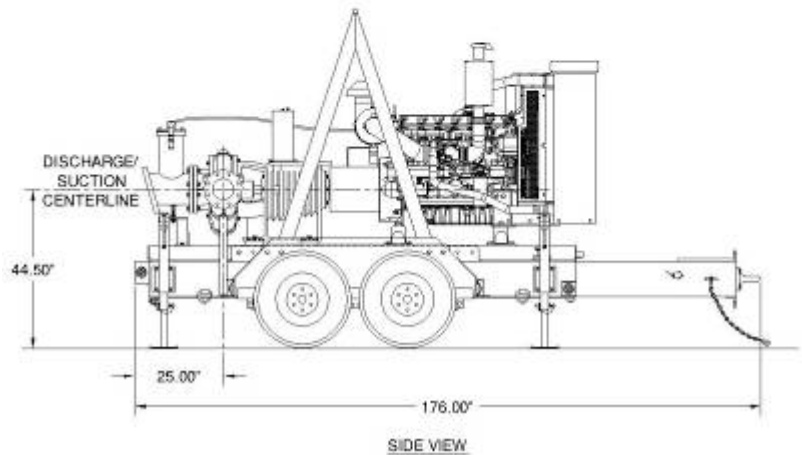
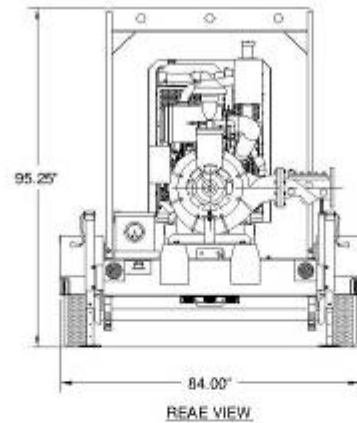

POWER PRIME™ PUMPS

P.O. Box 2248
Bakersfield CA 93303
800 647-7246
661-399-9058
FAX 661•399-3374
www.powerprime.com
sales @ powerprime.com

Power Prime™ is a registered trademark of Western Oilfields Supply Company. Features and Specifications are subject to change without notice.